

*Bel' Etoile*  
PATTERNS

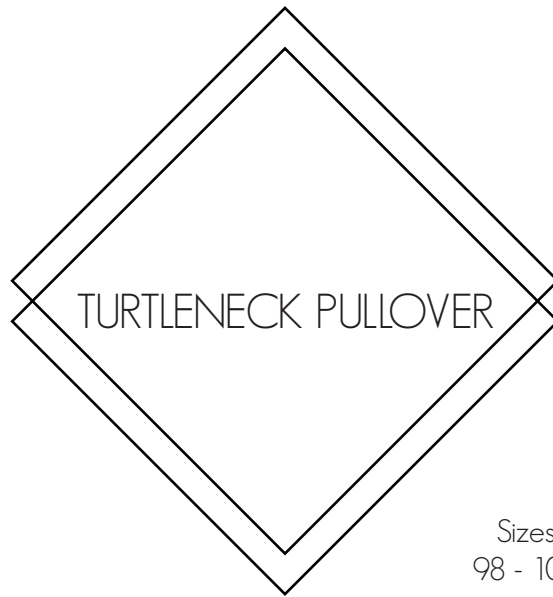

Sizes  
98 - 104

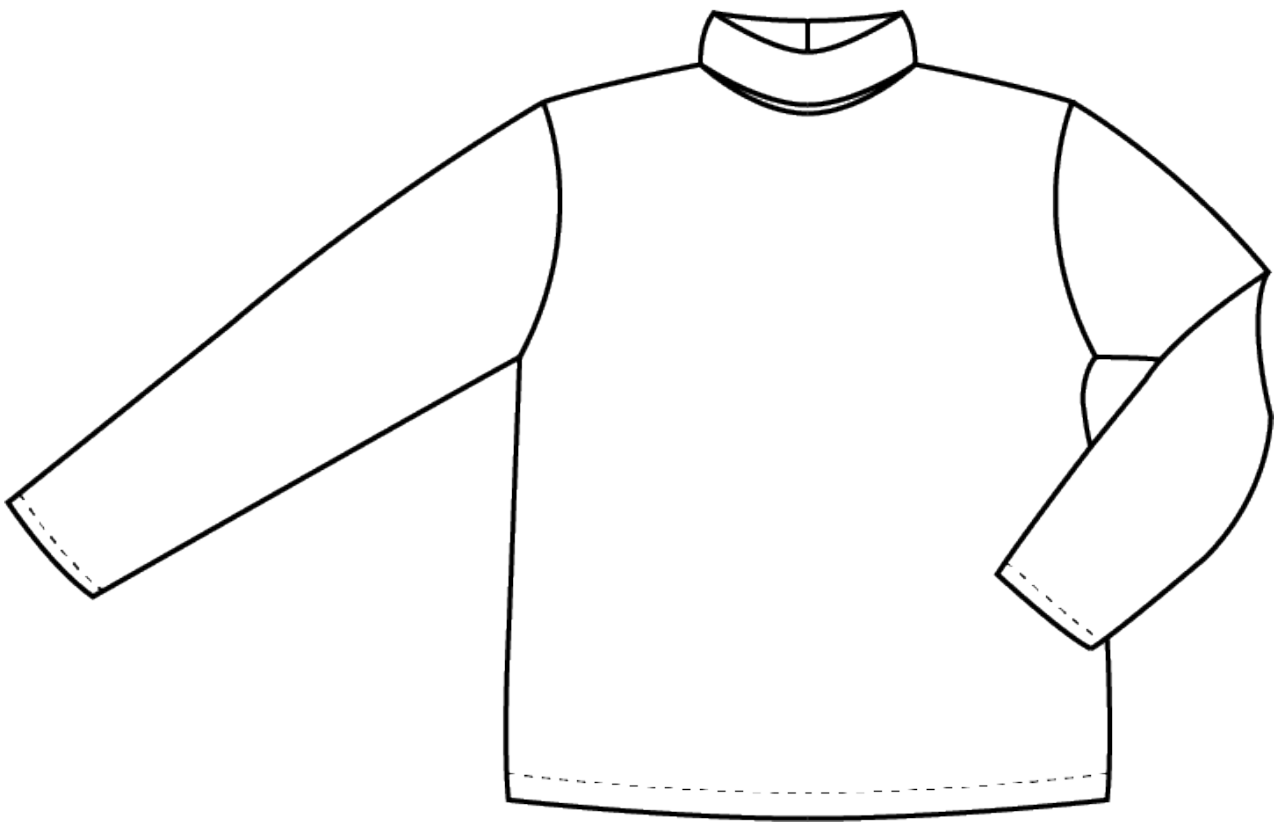

Questions or issues?  
Feel free to contact me:  
Facebook: [www.facebook.com/beletoileblog](https://www.facebook.com/beletoileblog)  
Email: [info@beletoile.com](mailto:info@beletoile.com)  
Instagram: @\_beletoile\_

Thanks for downloading this pattern!  
I would like to point out that all content of this pattern is copyright protected.  
It is not allowed to share the PDF file or printed copies of the pattern with others.  
This pattern is intended for personal use only.  
Any reproduction or resale of this pattern is forbidden by law.  
It is allowed to make copies for personal use.

The pattern may be used to sell finished items in small quantities, after written permission by the designer and by indicating the name of the pattern and the link to the websites.

Would you like to give a workshop with the pattern?  
Contact me for the conditions.

Happy sewing!  
Isabel

# Printing instructions

You can print the pattern on A4 or letter sized paper at home.

First download the pattern and open it again on PC / laptop /smartphone.

Make sure to set the printing to “real size or 100%”.

In the printer settings, select “automatic portrait/lying down “.

A test square is available on the first page of the pattern, make sure to measure it.

To save our environment, we recommend viewing the instructions on your tablet or computer.

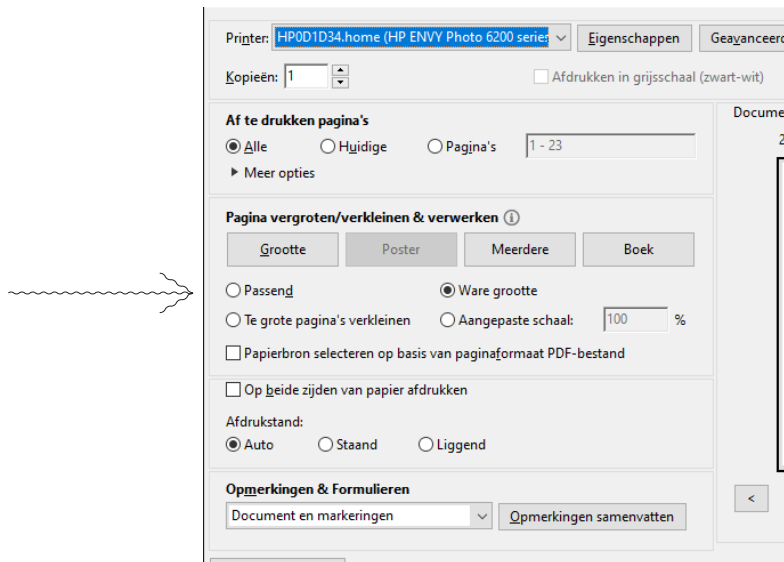

This pattern offers size printing.

Open the pattern in Adobe Acrobat PDF reader and click on the “layers” icon. Uncheck all layers you don't need, except the bottom layer (always keep this layer checked), that contains all required text and marks.

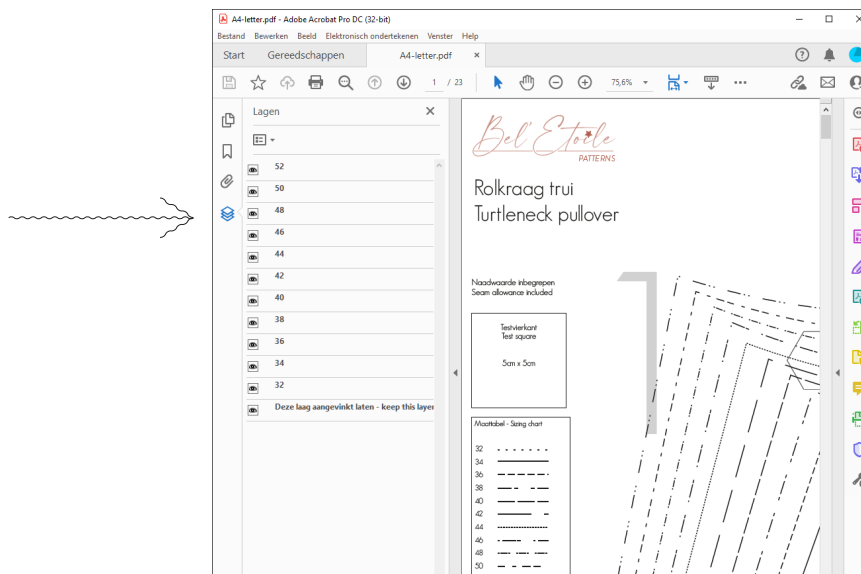

An A0 size file is included for copysshop printing.

About:  
 this turtleneck pullover is the perfect basic to wear on colder days.  
 The fit is comfortable, with long sleeves and a fitted turtleneck collar.

## Useful charts

### Size chart

*THE NUMBERS TELL THE TALE!*

Measure carefully before determining which size to make.

**There can be differences between ready to wear sizes and sewing pattern sizes.**

The bust circumference is the determining size for the shirt, use that measurement as a starting point.

Between 2 sizes? Go for the biggest one.

Size	98	104	110	116	122	128	134	140	146	152	158	164
Height	98	104	110	116	122	128	134	140	146	152	158	164
Chest	55	57	59	61	63	66	69	72	75	78	81	84

### Dimensions finished pieces

This table offers an overview of how much ease is added to each size and the length of each garment.

The length of the shirt is the back neck to hem measurement.

You can compare these measurements to a well fitting garment and make adaptations when necessary.

Size	98	104	110	116	122	128	134	140	146	152	158	164
Chest circumference pullover	60	62	64	66	68	71	74	77	80	83	86	89
Back length pullover*	38	40	42	43,5	45,5	47	49	51	52,5	54,5	56,5	58,5

### Recommended fabrics

This pullover was drafted for well stretching fabrics.  
 Eg. jersey or knitted fabrics

### Required amount of fabric

Fabric width: 140cm

Size	98	104	110	116	122	128	134	140	146	152	158	164
Fabric	65	70	70	80	80	110	110	120	120	125	130	130

## Seam and hem allowance

Seam and hem allowance are included in all pattern pieces.  
Seam allowance: 0cm at fold and 1cm around  
Hem allowance: 2cm for sleeves, 3cm for shirt

## How to tape pages together

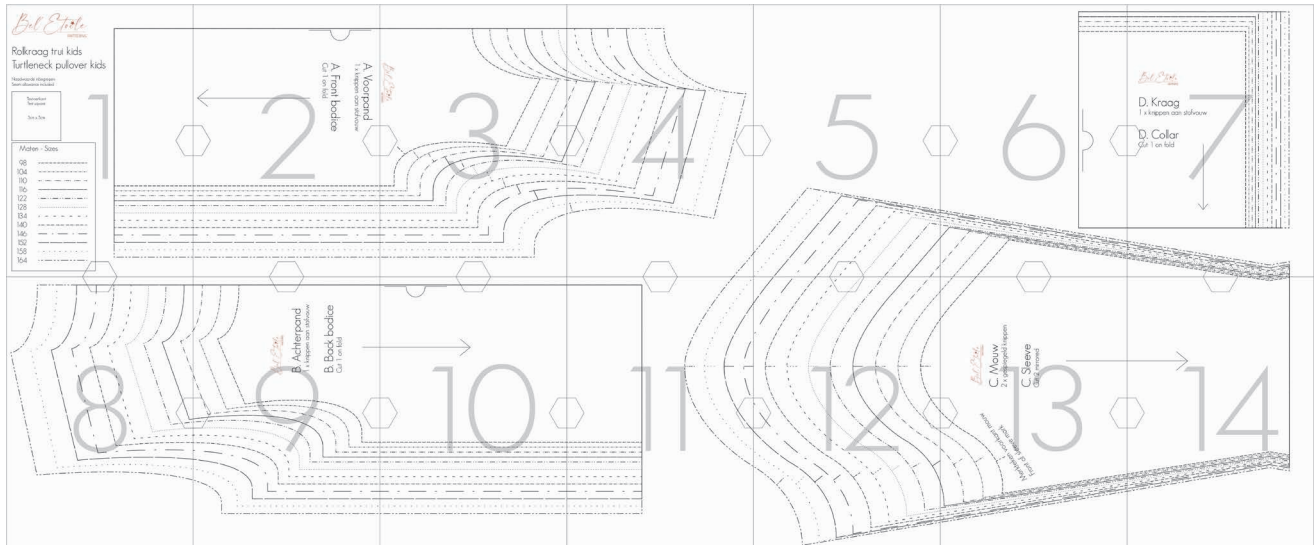

# Instructions

## 1. Shoulder seams

Pin front and back shirt together, right sides facing each other.  
Stitch shoulder seams.  
Press seams towards the back bodice.



## 2. Sleeves

Optionally, you can finish the sleeve hem with your overlocker or by using a zigzag stitch.  
Press the hem allowance of your sleeves 2cm inwards and fold back open, this helps you hem accurately later.

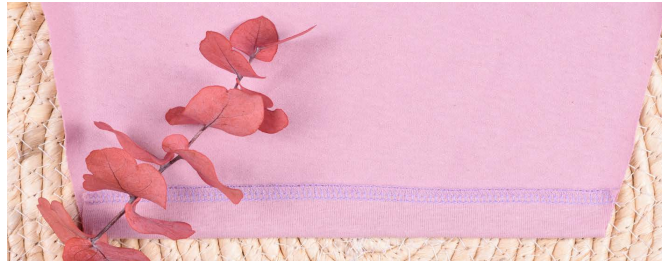

Pin sleeve into front and back bodice armhole, right sides facing.

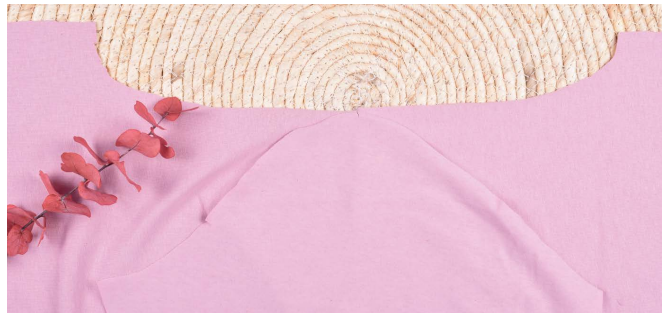

Stitch seam and press away from the shoulder seam.



### 3. Side seams and sleeve seams

Pin side seams of front and back bodice together, and do the same for the sleeve seams.

Stitch seams in 1 go.

Press seams and turn your shirt right side out.



### 4. Turtleneck collar

Fold collar in half, right sides facing.

Pin and stitch seam.



Fold and press collar in half again, wrong sides facing.

You'll get a tunnel.



Slide your collar over the neckline of your shirt and pin.  
Align the unfinished side of the collar with the neckline.  
Stitch all the way around, fold and press into place.



## 5. Hemming

Press sleeve hems 2cm inwards, wrong sides facing.  
Stitch with a stretch stitch and press.

Press pullover hem 3cm inwards, wrong sides facing.  
Stitch with a stretch stitch and press.

Press your pullover again and you're finished!

[www.beletoile.com](http://www.beletoile.com)  
[www.instagram.com/\\_beletoile\\_](https://www.instagram.com/_beletoile_)  
[www.facebook.com/beletoileblog](https://www.facebook.com/beletoileblog)